

RUBBISH CHUTE TECHNICAL NOTE

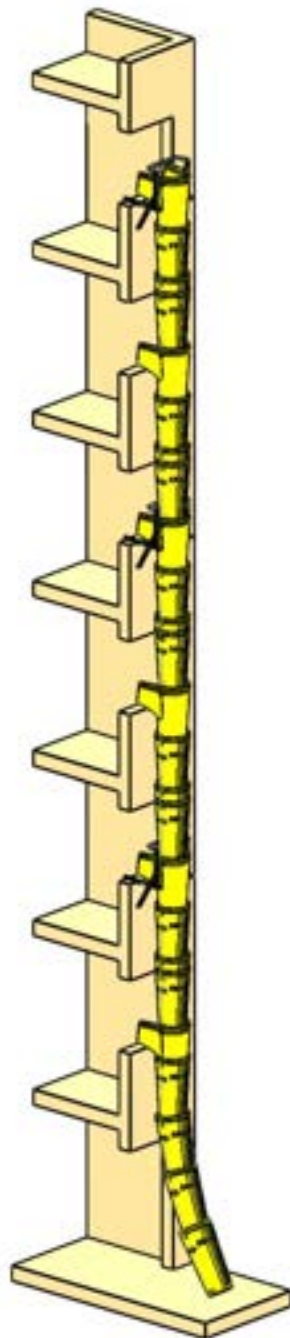

ORIGINAL TECHNICAL NOTE IN FRENCH

Haemmerlin - SAS
28, rue de Steinbourg - F - 67700 MONSWILLER
Tel. + 33 (0)3 88 01 85 00
welcome@haemmerlin.com – www.haemmerlin.com

SUMMARY

	Page
Warning, description and characteristics	3
Preparing the worksite and Calculation of the number of rubbish chutes needed	4
Installing the window fixing frame	5-7
Installing the scaffolding fixing frame	7-10
Installing the platform fixing frame	11-13
Attaching and disconnecting chains	14
Rubbish chute installation and usage instructions	15-17
Maintenance	17
For rubbish chutes from very high buildings	18
Installing the moderator	18-19
Rubbish chutes kits	20
Spare parts	21

Instructions

The HAEMMERLIN rubbish chute is the result of many years of research and perfecting to improve the quality and safety of the rubbish chute.

We nevertheless recommend respecting the following instructions to ensure you get the most out of the product whilst optimising safety conditions and respect for the environment.

Before installing or using the rubbish chute or any accessories, make sure that all users are fully aware of the instructions in this technical note.

This technical note should be easily accessible to users of the rubbish chute.

HAEMMERLIN disclaims any responsibility for any consequences due to improper use or installation of the rubbish chute and its accessories according to this technical note, as well as any consequences due to dismantling, modification or replacement of any parts with other parts supplied by a third party without written consent.

In the framework of its constant efforts to improve its products, HAEMMERLIN reserves the rights to alter materials at any time.

Description



Rubbish chute section
Code 318101001

Hopper chute section
Code 318102001

Chute moderator
Code 318107001

Safety clip with a safety catch
(exclusive to Haemmerlin)

Technical specifications for chute and hopper sections

- Materials: ecological polypropylene copolymer (fully recyclable)
- Operating temperature for chutes and loading hoppers: between 0 and 50° Celsius
- Breaking strength of chains: 1000 kg/chain (2205 lbs)
- Number of links per chain: 21
- Weight of chute section: 8kg
- Weight of hopper chute section: 8.65kg
- Total length: 1.10m (43")
- Usable length: 0.90m
- Internal diameter: 507/380mm (20"/11")
- Outside diameter: 515/395mm (20^{1/4}"/15^{1/2}")
- Overall width of chute section: 620mm (24^{1/2}")

Overall dimensions of the hopper chute section: 620 x 740mm (24^{1/2}" x 29")

Feel free to ask us for our complete installation guide for more technical information on rubbish chutes and accessories.

Preparing the worksite:

- Measure the height and distance between the starting point and the finishing point in order to calculate the number of chute sections required. In order to determine the number of chute sections required according to the height of the building, divide the height of the building by the usable length of the rubbish chute sections (0.90m). For example, for a building measuring 40m (130ft) high: $\frac{40}{0.90} = 45$ chute and hopper sections.
- Position the starting point so that users have full visibility of the rubbish chute.
- Depending on the set-up of the worksite, choose the appropriate fixing frame for anchoring the rubbish chute.

WINDOW FIXING FRAME SCAFFOLDING FIXING FRAME PLATFORM FIXING FRAME

Code 318103201

Code 318104501

Code 318103501

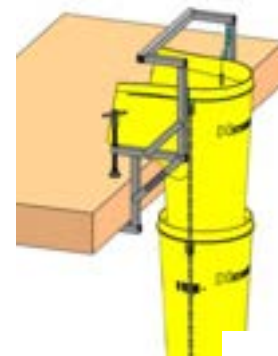
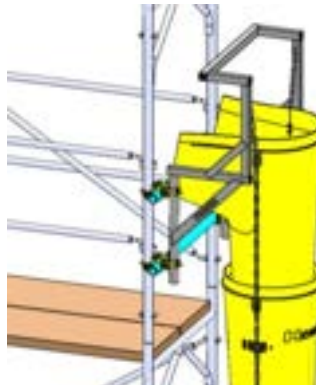
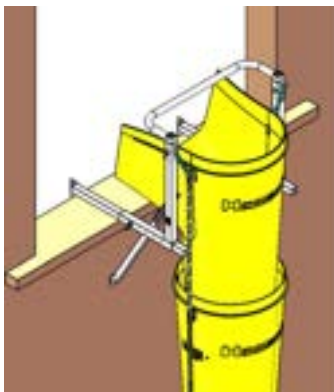

Calculation of the number of rubbish chutes needed

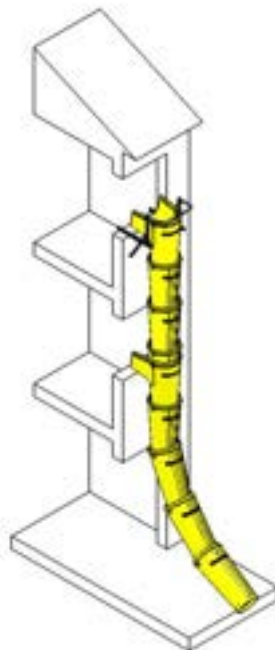
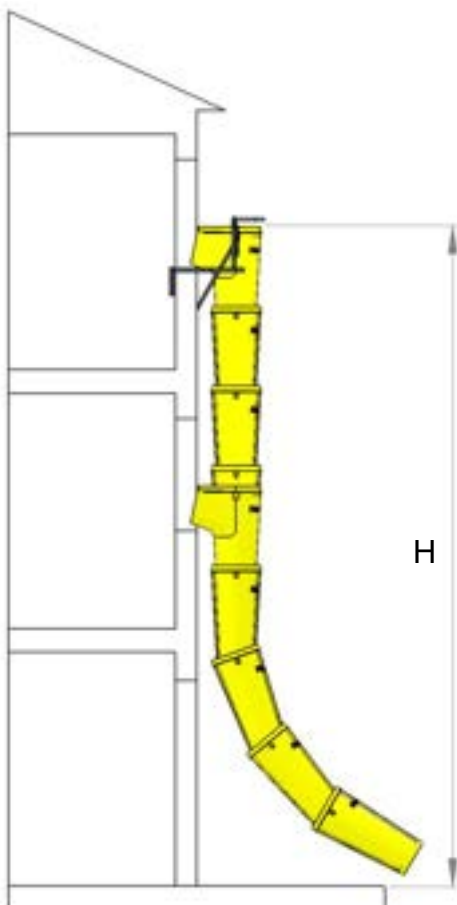

Overall length of a rubbish chute/hopper = 1,10m

Working length of a rubbish chute/hopper = 0,90m

N = number of chute sections required for a height of chute H

$N = H/0.90m$ (rounding up)

To achieve an angle, add a supplementary rubbish chute.

WINDOW FIXING FRAME

The window fixing frame is suitable for mounting to window openings, sills, parapets etc.

It is mounted to the building using the two strut jacks.

It can be mounted to walls of thicknesses between 200 and 400mm (8" and 16").

The maximum number of chute sections that can be attached to a window fixing frame, depends on the height of the building:

- For heights up to 40m, the maximum number of chute sections that can be attached to a window fixing frame is 10, i.e. a maximum distance of 9m between two window fixing frames.
- For heights up to 60m, the maximum number of chute sections that can be attached to a window fixing frame is 8, i.e. a maximum distance of 7.2m between two window fixing frames.
- For very high buildings, higher than 60m, we recommend installing a window fixing frame on each floor.

It is composed of:

- A > Sleeve (x2)
- B > Strut jack (x 2)
- C > Crosspiece (x1)
- D > Bolt (x4)
- E > Nut (x4)



Installation:

- Before installing the window fixing frame for rubbish chute kits, check the strength of the anchor point where it will be fixed (window recess, sill, parapet etc.). Take into account the weight of the chute sections as well as the potential weight of the debris, which may obstruct the rubbish chute in case of improper use.
- Measure the thickness of the wall at the anchor point where the window fixing frame will be installed.
- Insert the strut jacks (B) into the sleeve (A), then adjust the strut jack in the sleeve according to the thickness of the wall previously measured. Lock the strut jack in place in the sleeve using the bolts (D) and nuts (E).



- Repeat the process with the second strut jack and sleeve.
- Fix these two components to the anchor point keeping enough distance between them for receiving the crosspiece (C).
- Slot the crosspiece into place (C) and secure using the bolts (D) and nuts (E).

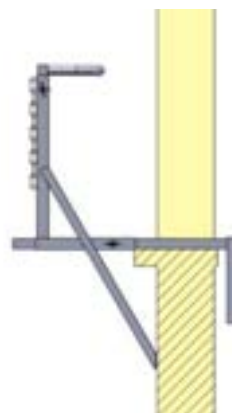
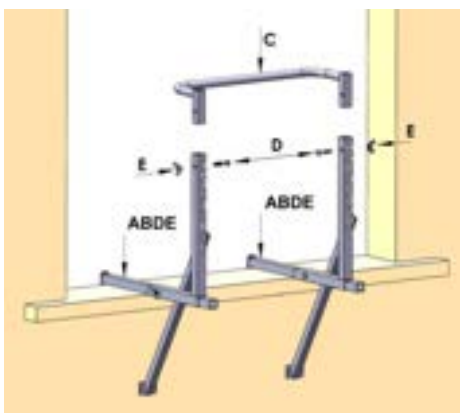

- Insert a plank between the inside of the wall and the supports to make the installation perfectly stable and to ensure proper distribution of the weight load on the wall, sill or parapet.

- The plank must be screwed or nailed securely to the supports of the jacks to prevent it from suddenly coming free.

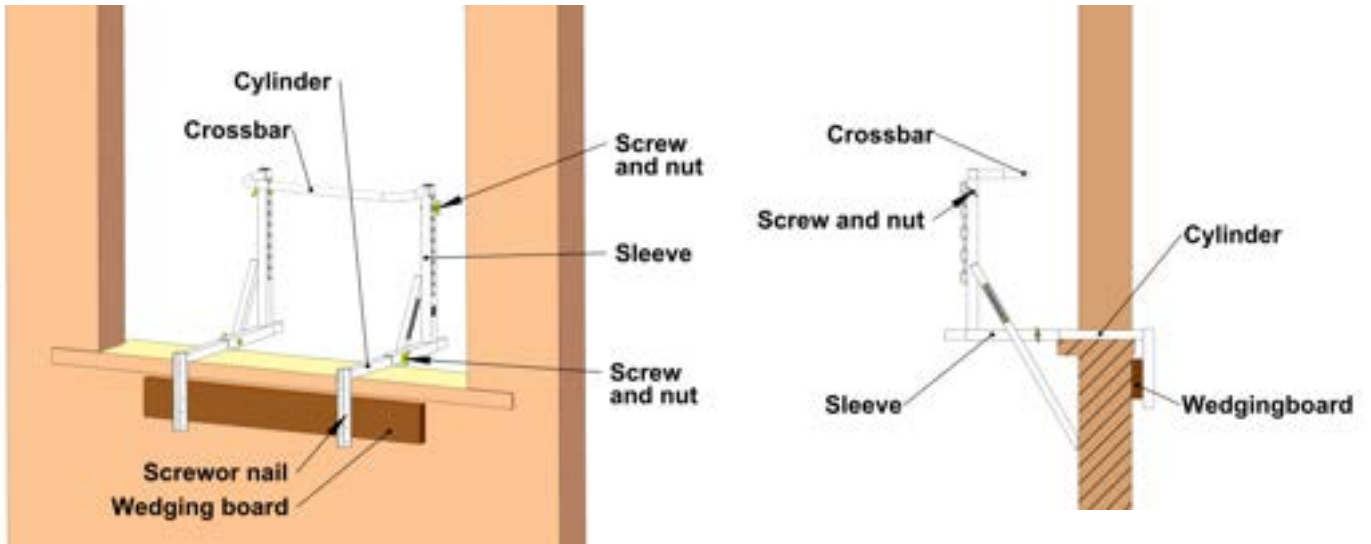

- Install the hopper and the chute sections in accordance with the installation and usage instructions.

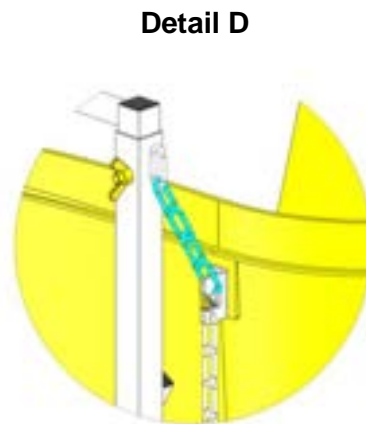
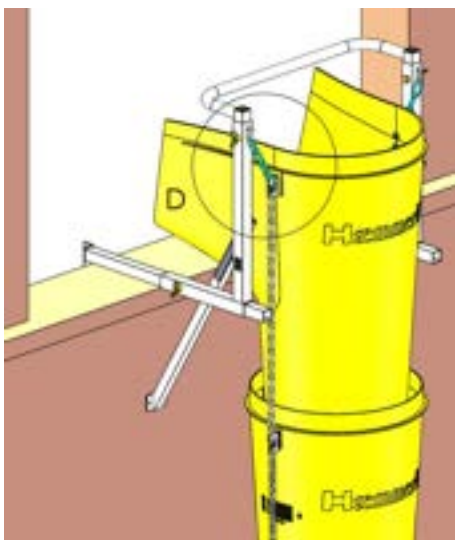
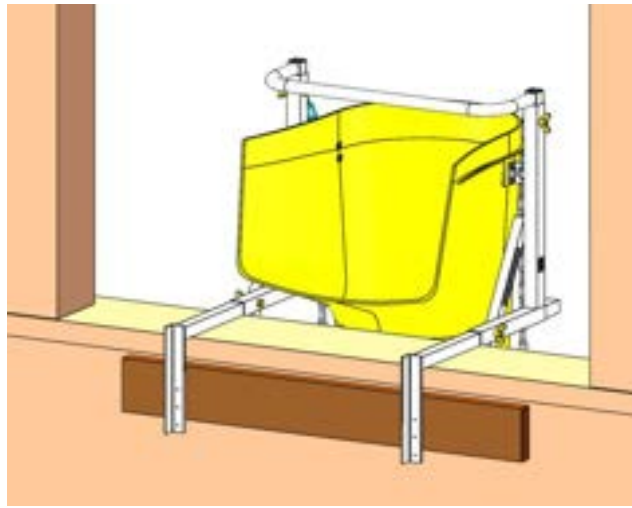
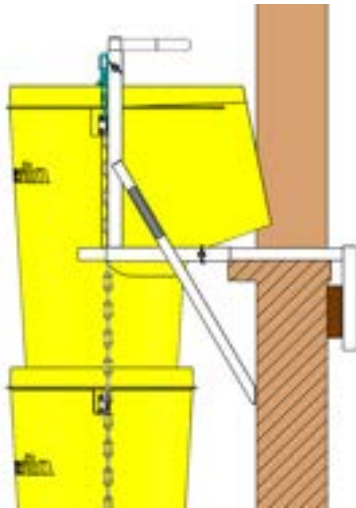

The chute sections can now be mounted to the window fixing frame.

EXAMPLE OF INSTALLATION ON A BUILDING BY MEANS OF WINDOW FIXING FRAMES

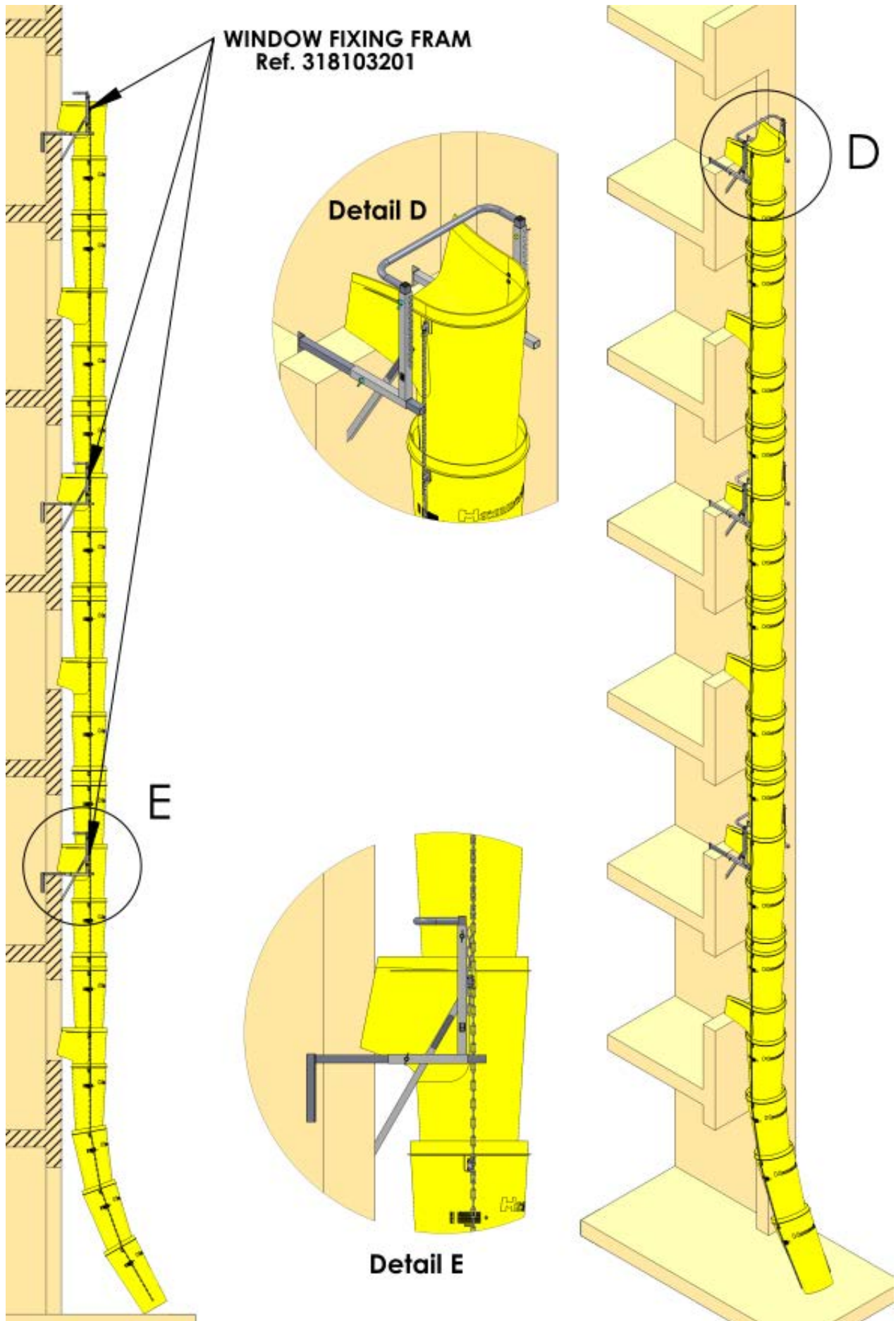

SCAFFOLDING FIXING FRAME

It is appropriate for scaffolding, metal structures etc.

It can be mounted to a tubular structure or scaffolding using orthogonal couplers or double couplers (D49). The couplers are not supplied with the scaffolding fixing frame.

The maximum number of chute sections which can be attached to a scaffolding fixing frame depends on the height of the worksite:

- For heights up to 40m (131ft), a maximum of 16 chute sections can be attached to a scaffolding fixing frame, representing a maximum distance of 14.4m between two scaffolding fixing frames. Moreover, an intermediate point of anchorage to the scaffolding is required between two fixing frames using a rope or a chain (not supplied).
- For heights up to 60m, the maximum number of chute sections that can be attached to a scaffolding fixing frame is 10, i.e. a maximum distance of 9m between two scaffolding fixing frames.
- For very high buildings, higher than 60m, we recommend installing a scaffolding fixing frame on each floor.

This consists of:

- A > Left/right bracket (x2)
- B > Upper crosspiece (x1)
- C > Scaffold tube (order separately)
- D > Orthogonal coupler (order separately)
- E > Double coupler (order separately)

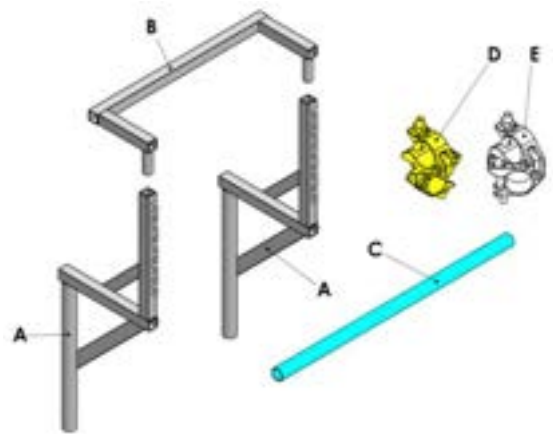

Installation:

- Before installing the fixing frame, check that the scaffolding is solid and anchored to the building. Take into account the weight of the chute sections as well as the potential weight of any debris that could obstruct the chutes in the event of improper use.
- The fixing frame can be attached directly to the scaffolding tower uprights or to specially placed scaffold tubes by means of orthogonal or swivel couplers.
- Install left/right bracket (A) by clamping the lower strut to the scaffold tube using two couplers (D or E) not supplied. Do not tighten the couplers securely straight away.
- Repeat the process for the second left/right bracket (A).

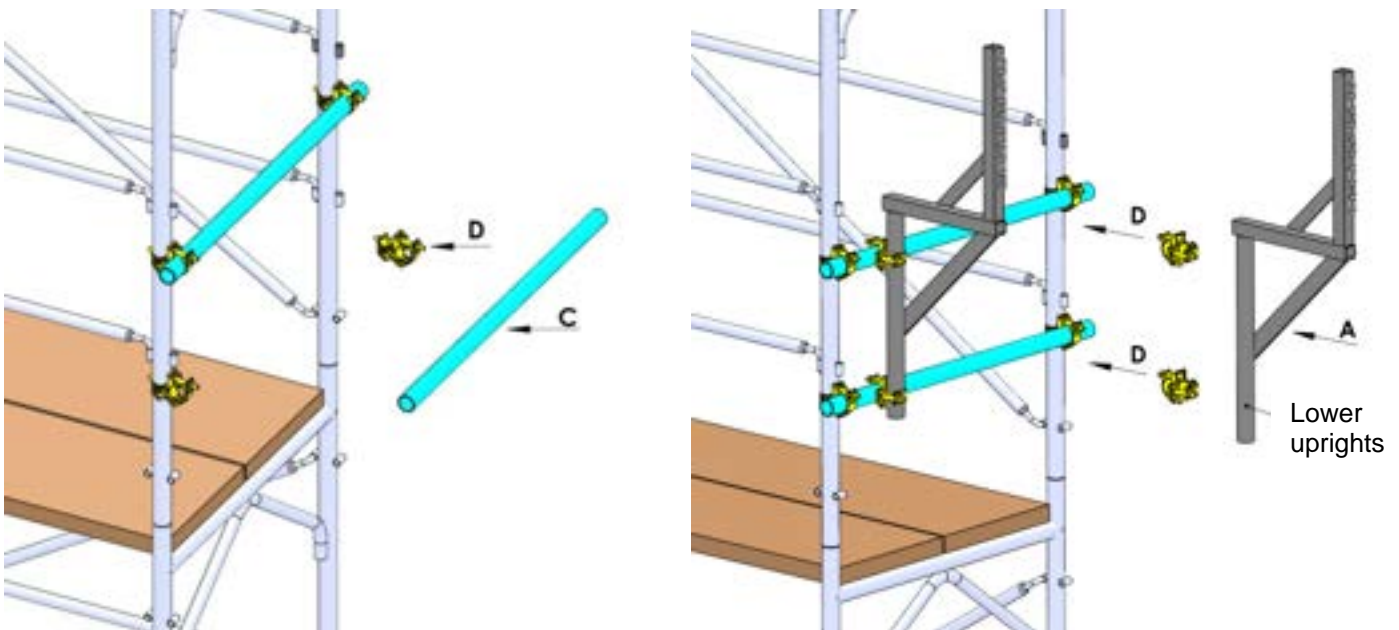

- Adjust the level and distance between the two left/right brackets (A) using the upper crosspiece (B) by fitting it into the upper struts of the left/right brackets (A).

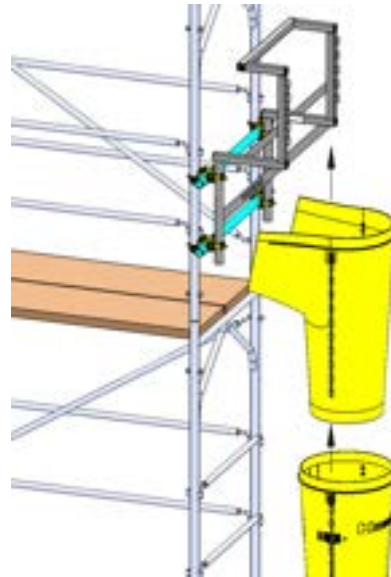
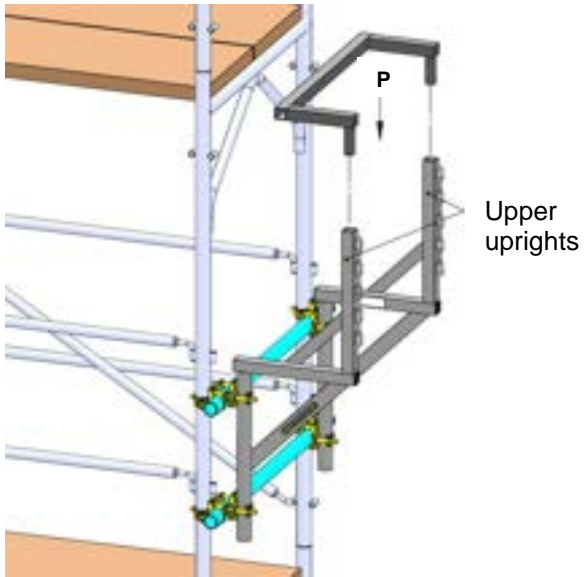

- Check that the left/right brackets are level (A), then tighten the assembly by pressing on the four couplers (D or E) until the fixing frame is perfectly stable in relation to the scaffolding.
- The scaffolding fixing frame is then ready for the chutes.
- Install the hopper and the chute sections in accordance with the installation and usage instructions.

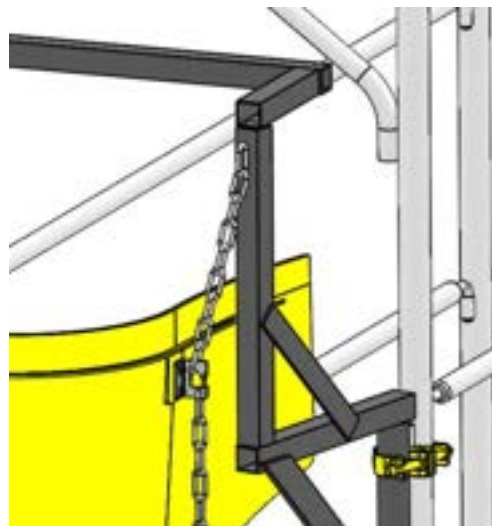
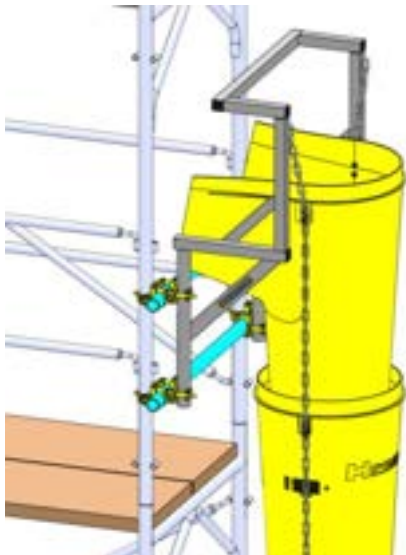

Detail of the chain attachment

Other examples of installation on scaffolding

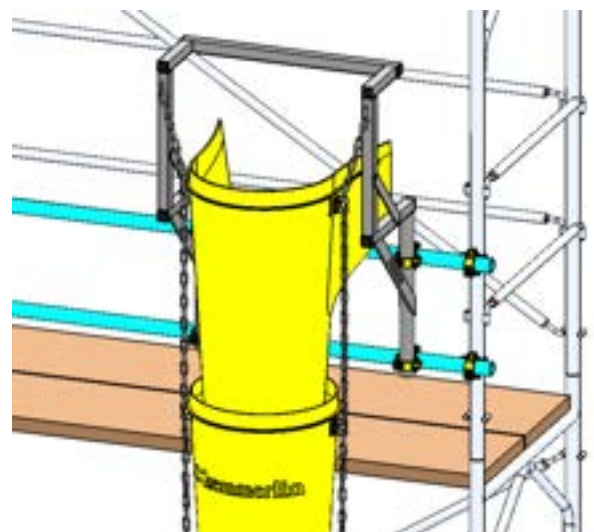
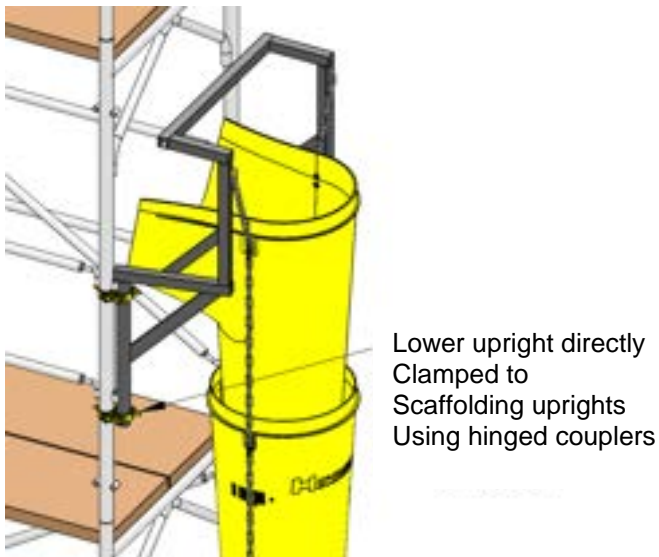

Installation on the front of the scaffolding

EXAMPLE OF INSTALLATION ON A BUILDING BY MEANS OF SCAFFOLDING FIXING FRAMES

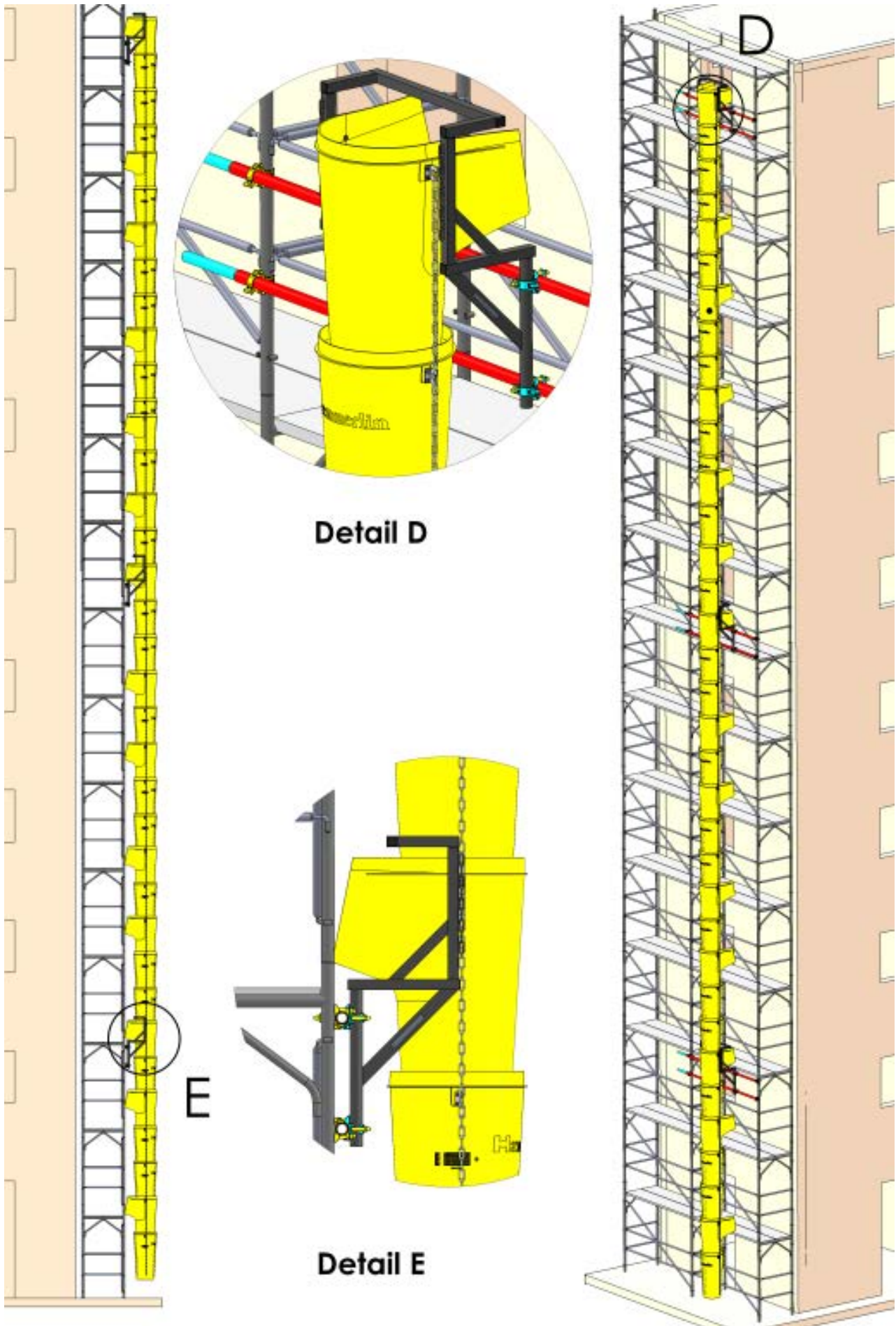

PLATFORM FIXING FRAME

It is intended for mounting to a concrete slab (on a balcony or terrace).

It can be mounted to concrete slabs of thicknesses varying between 150mm and 300mm (8" and 12") thanks to the two grip jacks.

The maximum number of chute sections that can be attached to a platform fixing frame depends on the height of the worksite:

- For heights up to 40m (131ft), a maximum of 16 chute sections can be attached to a platform fixing frame, representing a maximum distance of 14,4m between two platform fixing frames. Moreover, an intermediate point of anchorage to the building is required between two fixing frames using a rope or a chain (not supplied).
- For heights up to 60m high, the maximum number of chute sections that can be attached to a platform fixing frame is 10, i.e. a maximum distance of 9m between two platform fixing frames.
- For very high buildings, higher than 60m, we recommend installing a platform fixing frame on each floor.

This consists of:

- A > Left/right bracket (x2)
- B > Upper crosspiece (x1)



Installation:

- Before installing the platform fixing frame, check the strength of the slab, balcony or terrace. Take into account the weight of the chute sections as well as the potential weight of the debris, which may obstruct the rubbish chute in case of improper use.
- Engage one of the two left/right brackets (A) with the slab from above so that the slab is held tightly between the lower supports and the screw clamp plate and the lower strut butts up against the edge of the slab.
- Then tighten the assembly by turning the screw clamp handle so that the lower supports are firmly pressed against the underside of the slab. Do not tighten securely straight away.
- Repeat the process to attach the second left/right bracket (A).

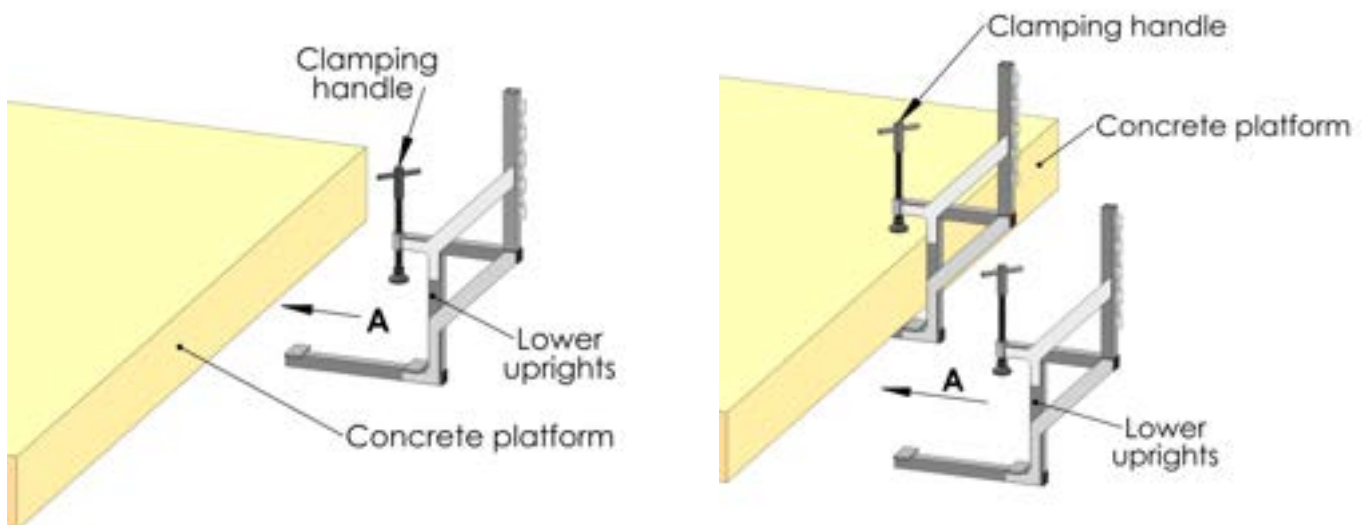

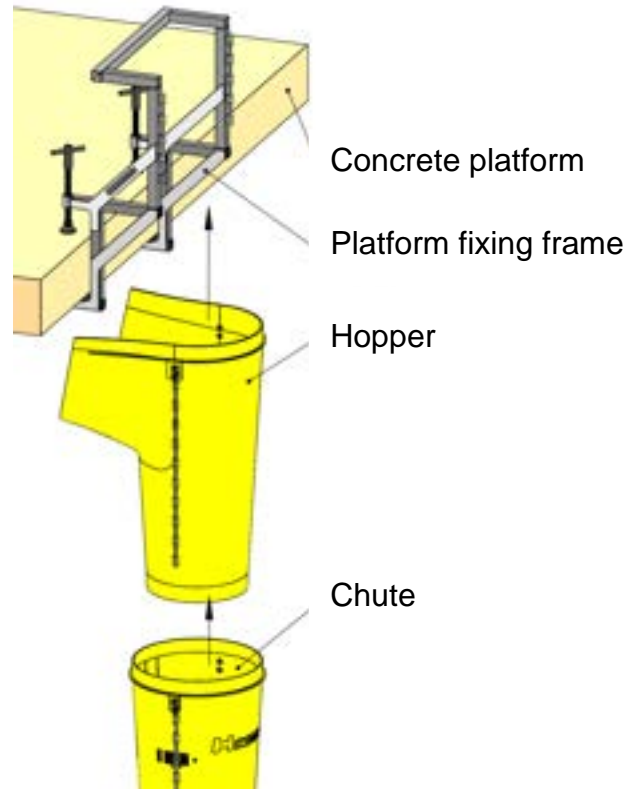
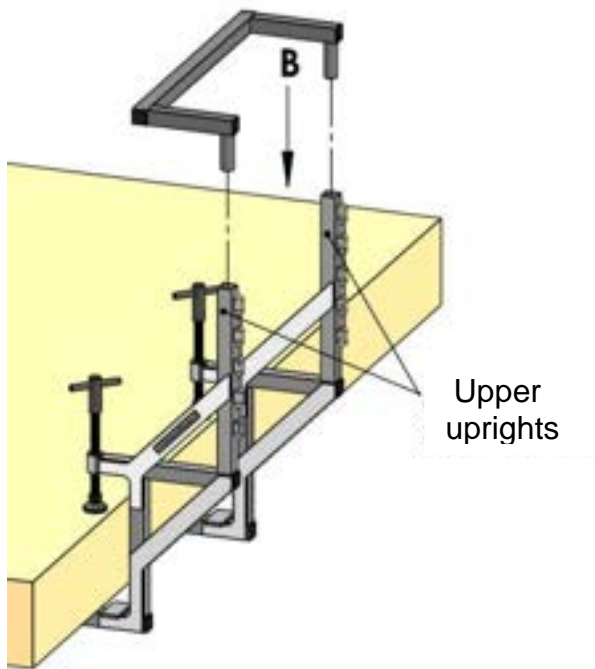

- Adjust the distance between the two left/right brackets (A) using the upper crosspiece (B) by fitting it into the upper struts of the two left/right brackets at the same time (A).
- Check that the installation is symmetric and level, then secure the installation by tightening the left and right grip jack handles so that the platform fixing frame is perfectly stable and secured to the building.
- The chute sections can now be mounted to the platform fixing frame.
- Install the hopper then the chute sections in accordance with the installation and usage instructions.

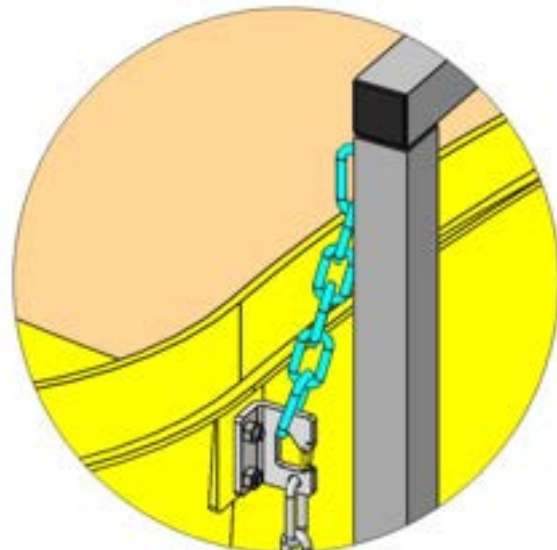
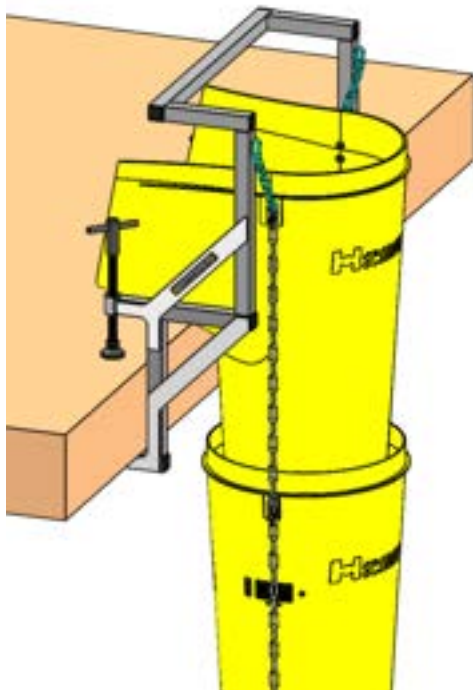

Detail of the chain attachment

Platform fixing frame ref. 318103501 has been certified by APAVE.
Certification report no. 2163266 dated 5 October 2021

EXAMPLE OF INSTALLATION ON A BUILDING BY MEANS OF PLATFORM FIXING FRAMES

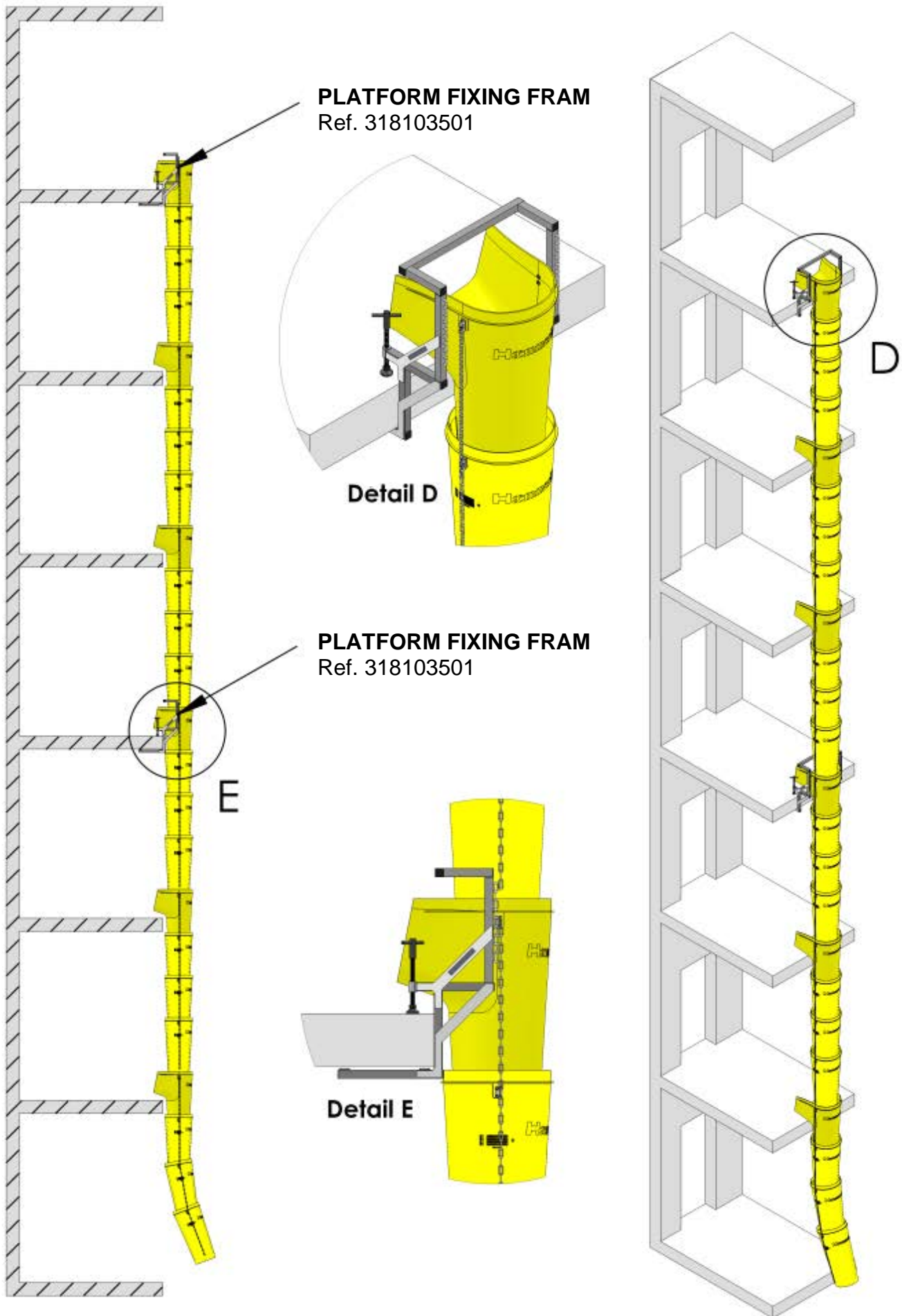

ATTACHING AND DISCONNECTING CHAINS

Attaching the chains:

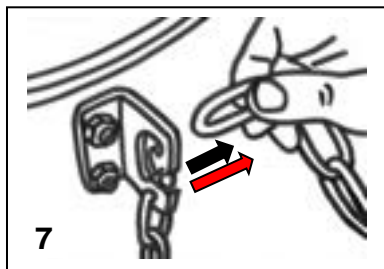
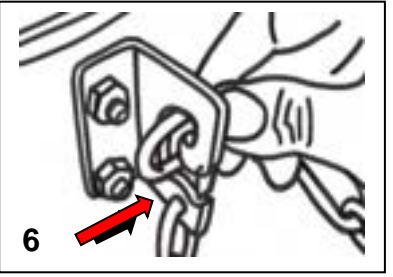
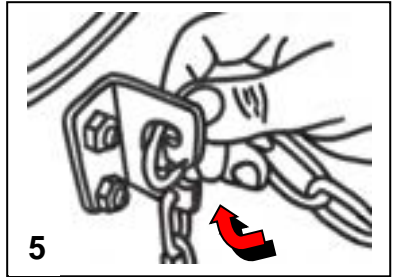
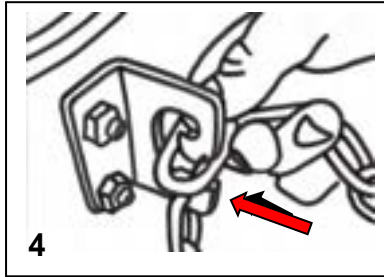
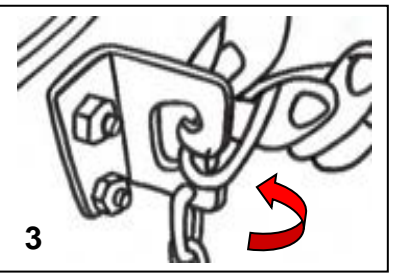
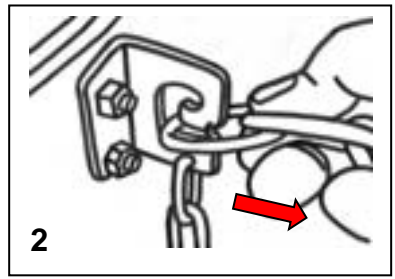
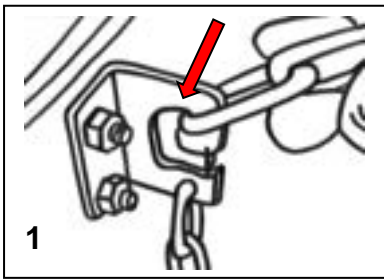
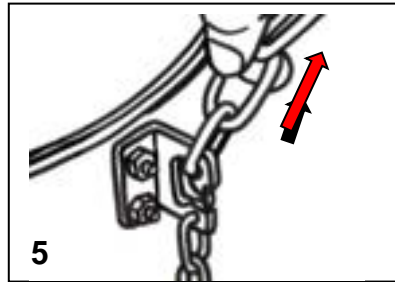
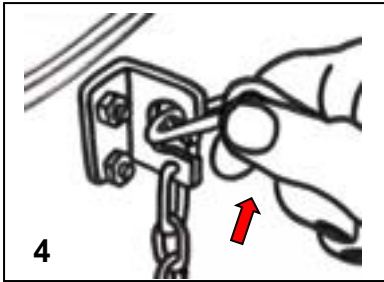
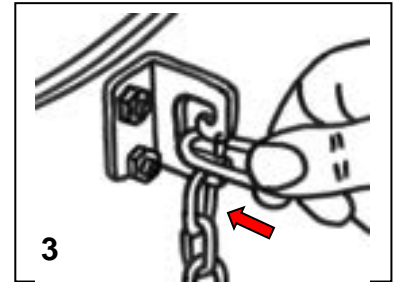
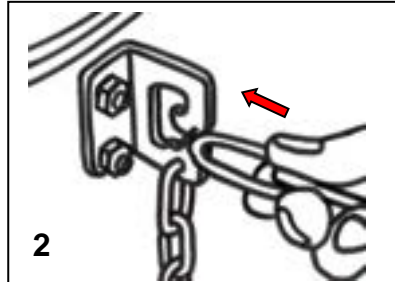
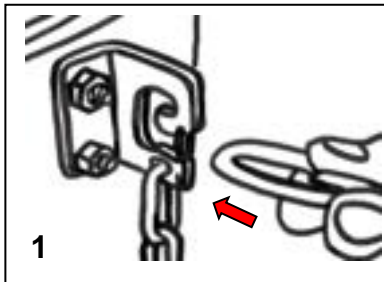

RUBBISH CHUTE USAGE INSTRUCTIONS

Chutes and hoppers can also be installed by means of an aerial platform or from scaffolding!

- Cordon off the hazardous area when installing and using the rubbish chute. People on the ground must wear a helmet and keep away from the chute sections when they are hoisted. People at the starting point to hoist the chute sections by means of a winch or rope must wear a fall arrest safety harness.
- Ensure that the starting and finishing points and the area around the installation are clean. Any place of work at height must be protected by guard rails.
 - Hoist the chute sections with a rope or winch. As the chute sections are hoisted by several people from the starting point, another person attaches the chute sections together at the finishing point.
 - When the loading hopper reaches the starting point, attach the chains of the fixing frame to the safety clips of the loading hopper.
- Only trained personnel are authorised to install, operate and dismantle the rubbish chute, the moderator and any accessories.
- Workers must wear PPE (safety gloves, safety helmet, safety glasses and safety footwear).
- The worksite must be strictly prohibited to the public.
- To ensure workers' safety, cordon off the hazardous area when installing and using the rubbish chute.
- Remember that it is dangerous and forbidden to bend over the opening of the rubbish chute or to stay close to the discharge end.
- Before installing the Chutes, ensure the resistance of the supporting structure.
- Before installing or using the rubbish chute, individual or collective fall protection equipment is required at each level of the building.
- Leave a gap of at least 1m (3ft) under the discharge end of the rubbish chute to prevent debris from building up and causing blockages. Check the container regularly to make sure this 1m gap is respected.
- Check regularly to make sure the debris is being completely evacuated to avoid blockages, particularly at the moderators and at the discharge end.
- Also ensure that dust does not stick to the inside of the rubbish chute. This would increase the deadweight of the installation, impede the passage of the large debris and could cause blockages.
- In order to not put too much stress on the rubbish chute, avoid having any significant bends. To ensure the rubbish chute curves smoothly, guide down a rope to the other end, take up the slack and attach at the starting and finishing points.
- When the rubbish chute only has one fixing frame or when the distance between 2 fixing frames exceeds 10m, install an intermediate anchoring point to the building by means of a rope, strap or chain.
- Provide a tarpaulin for above the container to prevent dust from lifting and spreading.
- Only use the fixing frames for attaching the chute or hopper sections. They are not intended for any other use than those described in this technical note.
- Do not use the chutes when the ambient temperature is below 0° Celsius.

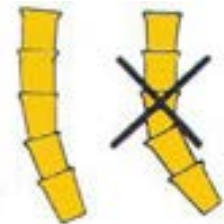

Before using the installation, check that each of the chains is securely attached to the corresponding anchorage plate.

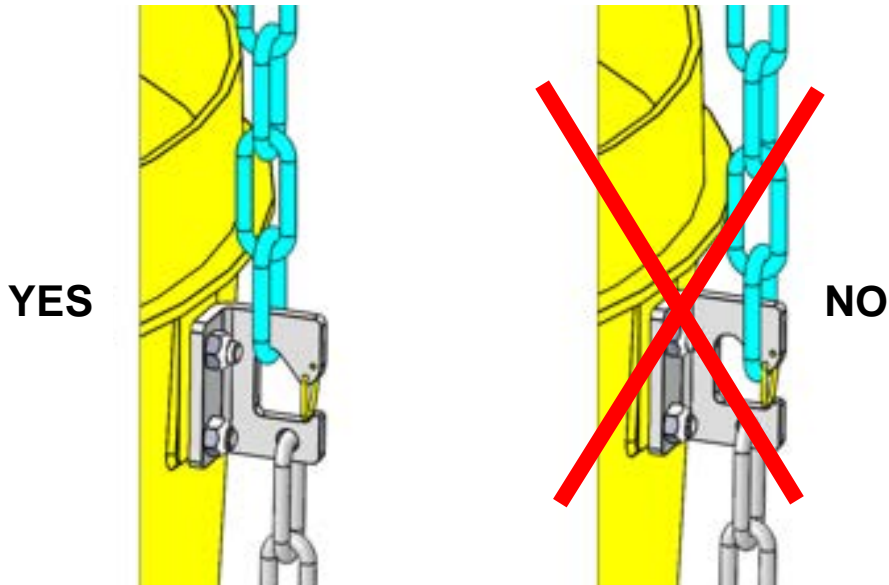

- When installing intermediate loading hoppers, ensure that the chute sections above the hoppers are always properly aligned with the hoppers to prevent debris from falling onto the flared part of the hoppers as this could seriously damage them.

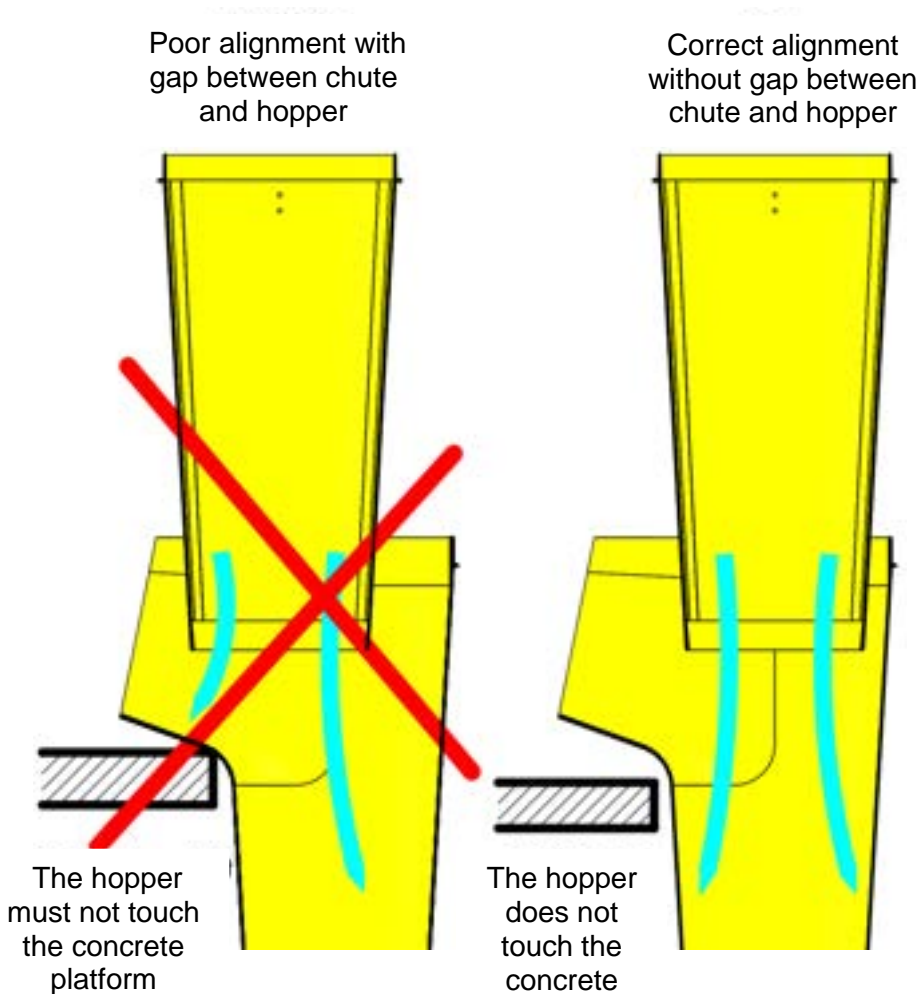

- Make sure that the flared part never comes into contact with a concrete slab or any other part of the building as this could seriously damage it.

The rubbish chute is now ready for use.

MANDATORY SAFETY RULES:

- **DO NOT** install or use the rubbish chute, moderator or accessories in high winds or in stormy weather.
- **DO NOT** walk under the rubbish chute.
- **DO NOT** allow members of the public to approach, stay under or walk under the rubbish chute.
- **DO NOT** stay around the discharge end unless installing, checking or carrying out maintenance on the rubbish chute and moderator, making sure that nobody inserts any materials.
- **DO NOT** use the rubbish chute, moderator or anchorage accessories as a foothold.
- **DO NOT** use the rubbish chute or moderator for transporting people.
- Use the chutes on a rolling scaffold.
- **DO NOT** use the rubbish chute or moderator for any other use than their intended use.
- **DO NOT** introduce large objects or debris, which may obstruct the rubbish chute, particularly at the moderator section.
- **DO NOT** use a moderator if there is an intentional bend at the end of the rubbish chute.
- **DO NOT** send fresh concrete or liquid waste down the rubbish chute.
- **DO NOT** send objects or debris weighing more than 5kg (11lbs) down the rubbish chute. This may damage the chute sections or the moderators.
- **DO NOT** send long or bulky objects down the rubbish chute. This may obstruct or damage the chute sections or the moderators.

MAINTENANCE:

- Check the rubbish chute's anchor points to the building or scaffolding daily.
- Check the chains and anchorage plates on the chute sections daily.
- Check that each chain is securely attached to the anchorage plate daily.
- Check that the moderators are securely attached to the chute sections daily.
- Clean the inside of the chute sections and moderators regularly to prevent blockages.
- Check that no debris is blocking the rubbish chute periodically.
- As soon as the chute sections, moderators or accessories show signs of wear, which may represent a risk to the user or to the environment, dismantle and replace with parts in good condition.
- Workers must wear PPE (safety gloves, safety helmet, safety glasses and safety footwear) when carrying out maintenance.

FOR RUBBISH CHUTES FROM VERY HIGH BUILDINGS:

For very high chutes we recommend a fixing frame on each floor for the following reasons:

- Easier to install because assembly of the chute sections and hopper on each floor is lighter and therefore more manageable.
- As the building gets higher, a new fixing frame should be installed, otherwise you will have to wait for the the next floors to be built to install the fixing frames.
- This ensures the rubbish chute is properly aligned and rigid.
- If a chute or hopper part wears out prematurely, the latter is easier to replace because it is more accessible and the assemblies are lighter.
- This means it is easier to adjust the distance between 2 chute or hopper parts because they are more accessible and the assemblies are lighter.
- Operators are safer because the chute and hopper assembly on each floor is lighter and therefore more manageable.
- From very high buildings, do not create a bend at the bottom of the chute to avoid excessive wear and tear on the lower parts.
- The chute sections and hoppers at the bottom of the chute will be more stressed because they are installed right at the start of construction, as soon as the 1st floor is completed.
- These chutes and hoppers will therefore get heavier use than those above for the entire period of construction because the debris evacuated from the upper floors is constantly accelerating up to a speed capped at about 200km/hour.
- For this, we recommend the installation of moderators approximately every 10m to slow down the speed of falling debris and wear and tear on the chutes and hoppers.

MODERATOR:

La durée de vie d'une goulotte peut varier considérablement dans un sens comme dans l'autre en fonction des éléments ci-dessous :

- Nature des gravats (abrasifs, tranchants, ...).
- Taille et poids des gravats (chocs et frottements plus importants pour des éléments lourds et volumineux).
- Grandes hauteurs (très forte accélération augmentant considérablement les chocs et les frottements).
- Coude prononcé à l'arrivée (les goulottes situées dans le coude sont celles qui subissent le plus de chocs et de frottements).

Pour les bâtiments de très grande hauteur, la durée de vie des goulottes peut être augmentée, à condition d'installer des ralentisseurs à gravats environ tous les 10 m, directement au-dessus des trémies de chargement intermédiaires.

Le ralentisseur permet de ralentir la vitesse de chute des gravats et donc de réduire considérablement les chocs et les frottements et donc l'usure des goulottes. Le ralentisseur génère aussi une réduction importante de la propagation des poussières et du bruit. Il est léger, peu encombrant et très facile à mettre en place sur une goulotte au moyen de 3 boulons. Il peut s'adapter à n'importe quelle goulotte et à n'importe quel endroit de la descente.

Il est rappelé que le ralentisseur est une pièce d'usure qui permet de limiter la détérioration trop rapide des goulottes et trémies. De ce fait, la durée de vie du ralentisseur sera nettement inférieure à celle des goulottes et trémies. Par conséquent, il sera nécessaire de le remplacer régulièrement.

Installing :

- 1) Turn the chute or hopper section to be fitted with a moderator upside down.
Place the moderator on the chute or hopper section so that the 4 ribs on the inside of the moderator fit into place on the narrow end of the upside-down chute section.
- 2) Drill three Ø 9mm (^{3/8"}) holes into the chute section through the holes in the moderator, then remove the burr.
- 3) Fasten the moderator to the chute section using the three HXBT M8 x 25 bolts and Ø 8mm (^{5/16"}) washers.
Insert the bolts so the bolt heads are on the inside of the chute section. The nut and washer should be fastened on the outside of the moderator.
- 4) Once the moderator has been securely assembled, the chute or hopper section is ready to be installed onto the rubbish chute.

1 PLACE THE MODERATOR ON THE UPSIDE-DOWN CHUTE OR HOPPER SECTION

BOTTOM OF CHUTE OR HOPPER

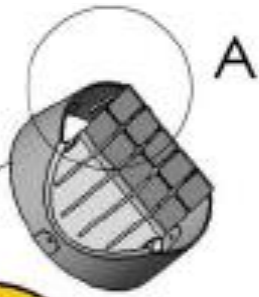

DETAIL A



2 DRILL THREE Ø 9MM (3/8") HOLES INTO THE CHUTE SECTION THROUGH THE HOLES IN THE MODERATOR, THEN REMOVE THE BURR

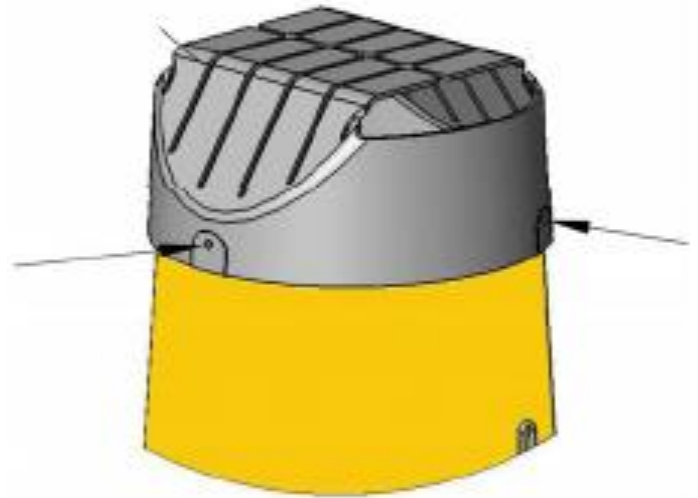

3 FASTEN THE MODERATOR TO THE CHUTE SECTION USING THE THREE HXBT M8 X 25 BOLTS

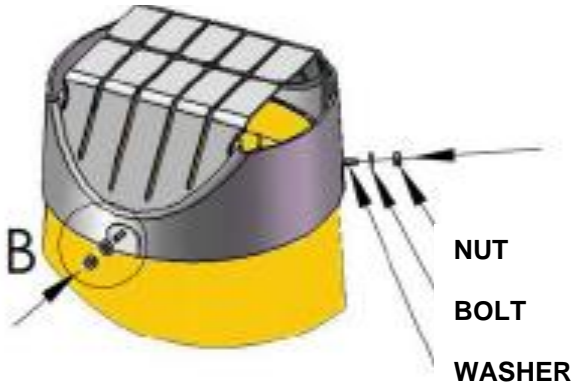

DETAIL B



INSERT THE SCREWS SO THE SCREWS HEADS ARE ON THE INSIDE OF THE CHUTE SECTION
NUTS AND WASHERS SHOULD BE FASTENED ON THE OUTSIDE OF THE MODERATOR.

4 SECURELY ASSEMBLED SECTION CAN BE INSTALLED ONTO THE RUBBISH CHUTE

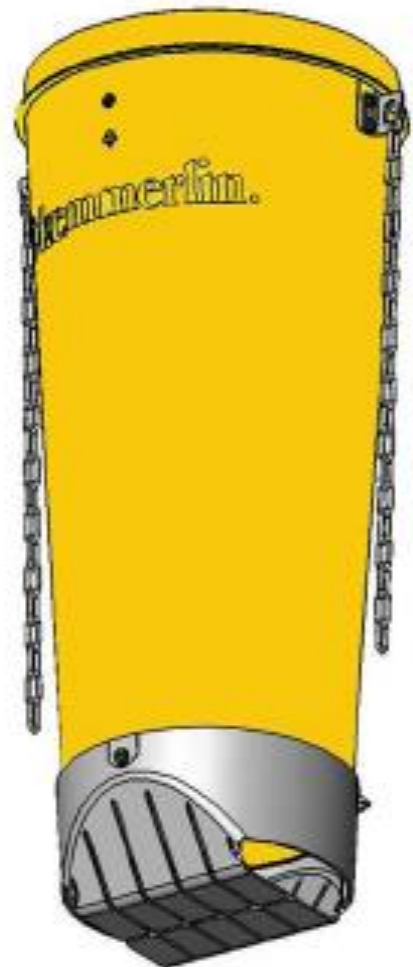

RUBBISH CHUTES KIT

Kit of 8 rubbish chutes + 1 hopper + 1 window fixing frame

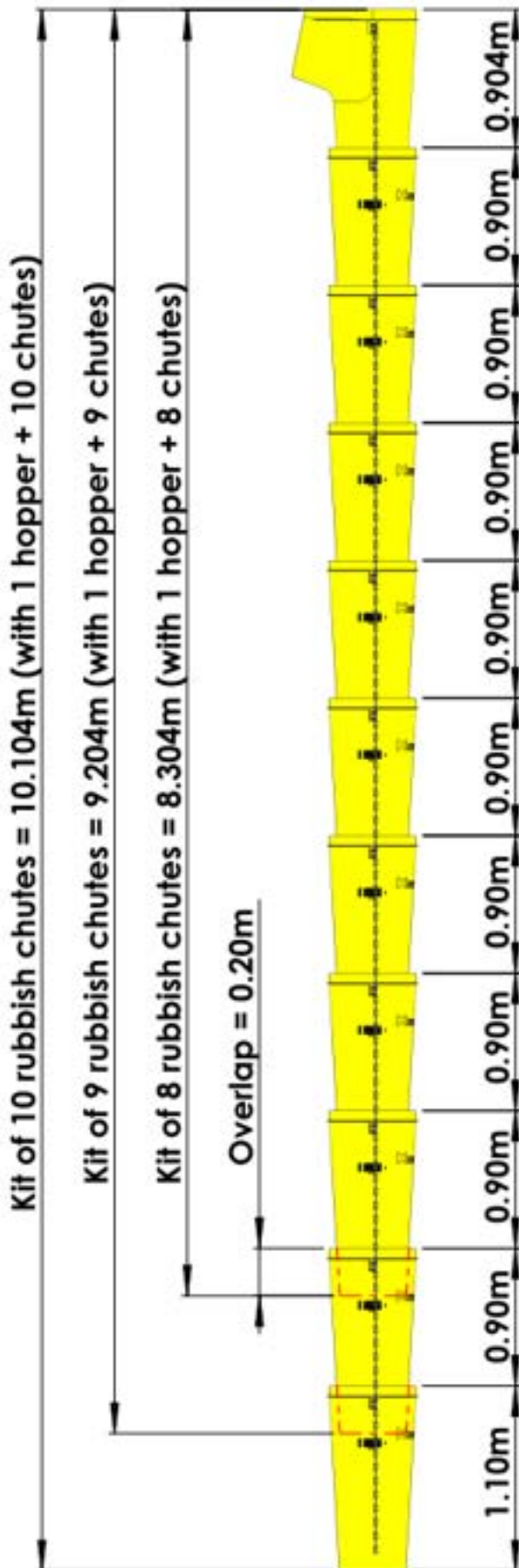

SPARE PARTS:

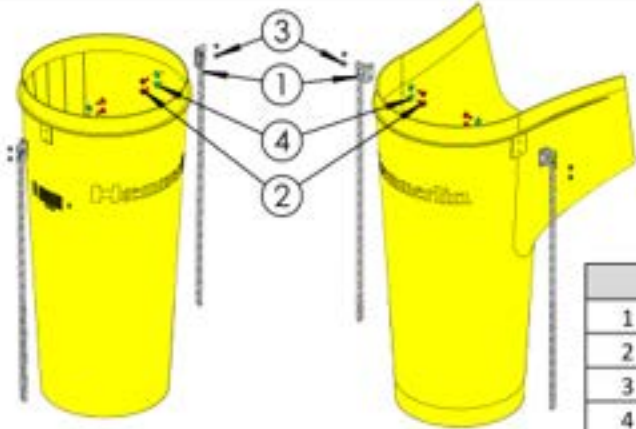

Name CHUTE/HOPPER			
1	281881100	Fixing part	2
2	281881101	Screw RL M8-25 EZ	4
3	201020800	Nut H, M8 brake EZ	4
4	202090700	Washer Ø8.4x22x1.5 EZ	4

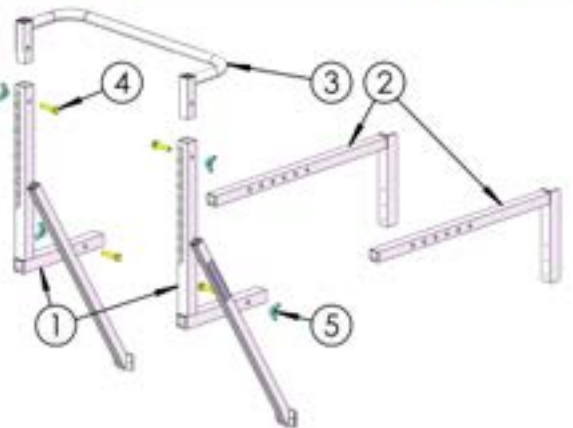

Name WINDOW FIXING FRAME			
1	HA19096	Sleeve	2
2	HA19102	Cylinder	2
3	HA19106	Crossbar	1
4	280121800	Screw RL M12-60 EZ	4
5	/	Wing nut M12 EZ	4



Name SCAFFOLDING FIXING FRAME			
1	419242200	Right/left part	2
2	419242400	Upper crossbar	1
3	240106200	Stopper for square tube 40x40x2	8

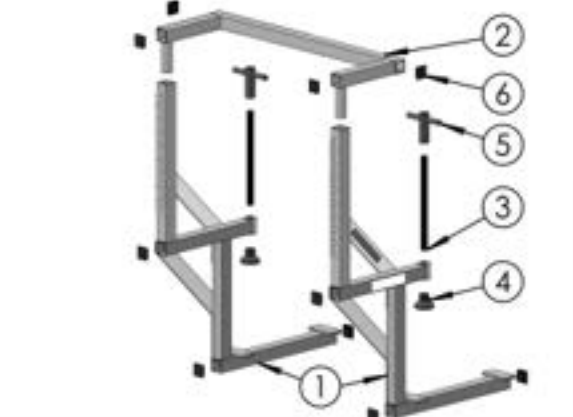

Name PLATFORM FIXING FRAME			
1	419216000	Right/left part	2
2	419242400	Upper crossbar	1
3	200022000	Dowel screw M20-200 EZ	2
4	201112200	Ball joint baseplate M20 Ø60	2
5	201112100	Fixed mandrel nut M20	2
6	240106200	Stopper for square tube 40x40x2	10